



# OPEN ACCESS INTERNATIONAL JOURNAL OF SCIENCE & ENGINEERING

## Power Factor Corrected Supply Created on Half Bridge LCC Resonant Converter

**Harish Kumar Dhiman**

*Department of Electronics and Communication Engineering, AKTU Lucknow, Uttar Pradesh, India*

*E-mail: mwharish10@gmail.com*

**Abstract:** *This paper proposes the design of a Power Factor adjusted power supply voltage DC utilizing a half bridge LCC series-parallel resonance converter. The DC power supply has a DC 400V input voltage and a DC 100V output voltage. Variable frequency control regulates voltage under various load conditions. MATLAB is accomplished to simulate the system performance. Testing is carried out to back up the findings.*

**Keywords:** *Resonance Converter, DC Supply, Half Bridge LCC Resonance Converters*

### I. INTRODUCTION

Resonant power converters have seen a resurgence of interest as the desire for smaller and more efficient power supply for squeezed electronic apparatus has increased. The proper and reliable functioning of electrical and electronic device is dependent on the equipment's power source. The power supply's design is extremely difficult due to the high expectations on functional capabilities, weightiness, measurements, dependability, and also the cost. When a power supply offers regulated power at the needed voltage consideration and current consideration for a certain load state, it performs better. This can range from a portion of watt to the limited thousand watts and from a narrow volts consideration to thousands of volts consideration in both DC voltage supply and AC voltage supply, and from limited cycles to a few thousand cycles in power electronics. It's also critical to have a higher level of efficiency. Low power losses and low frame are important goals. Power electronics has advanced significantly in the previous decade, leading in the creation of dependable, light-weighted, and highly-efficient power structures.

Resonant converters' soft switching principle makes them ideal for higher-frequency, higher-power of applications consideration. The LCC resonant converter is one of the most used converters topologies. A capacitor in the series configuration is additional to the resonance tank in an LCC resonance converter, which is similar to a parallel resonance converter. As a result, series-parallel resonance converters are sometimes known as LCC resonance converters.

Benefits of the resonance converters are renowned: higher powered densities, high efficient and reduced electro-magnetic nosiness. A part from this, a downside of that type of converter is it cannot be proficiently Configured or functioning with appropriated load variations or when an adaptable voltage of

output is needed. This makes limitation to the area of use of this kind of system. Converter created on configuration with two reactive components, such as series-parallel type resonance converter, are specimens of this type of converters with two components of reactive elements, although the operating situations are inadequate. The use of a configuration with three reactive elements is another method of designing LCC resonant converters. High-order of converters has better features than second-order converters, such as higher performance, high reliability, and efficiency. Furthermore, using higher-order resonant tanks allows you to benefit from parasitic component which is considered capacitances and inductances.

### II. RESONANCE CONVERTER CIRCUIT EXAMINATION

Converters founded on this configuration with two reactive types of components, such as series-parallel resonance converter, are specimens of converter with two components which is reactive type, although the functioning situations are inadequate. The use of a configuration with three reactive elements is another method of designing LCC resonant converters. High-order converter has advance function than secondary-order converter, such as higher performance, high reliability, and efficiency. Furthermore, using high-order resonance tank allows you to benefit from parasitic capacitance and inductance. This enables the use of common AC analysis techniques. The essential factor of input voltage which is square in nature is feed to the resonance tank circuit network using first harmonic approximation technique, and the resulting sinusoidal wave of currents and voltages in the resonance circuit are determined by the application through standard AC examination.

When sine wave voltage rectified by passing through the rectifier, Average values is obtained by way of the resulted DC voltage at the output in the case of a rectifier with output filter using an

inductor. In capacitive filtering, a square voltage is applied as an input to the resonance filter, and a sinusoidal current is fed in the rectifier. The essential frequency element of the square wave's voltages is employed to simplify the complexity of the examination. When employing an AC examination, Figure 2 shows the equivalent frequency domain formulation of the equivalent resistance to utilize in loaded to the resonance circuit.

The input voltage  $E_{ac}$  (rms) is given the eq. (1), and the current  $I_{ac}$ (rms) is given by eq. (2).

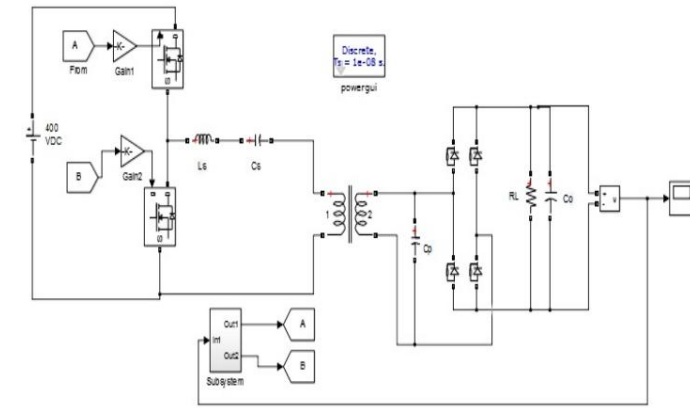

Fig. 1 LCC resonant converter circuit in MATLAB

The connection to the voltage after rectification  $E_o$  and the rms input voltage  $E_{ac}$ (rms) illustrated by Eq. (3)

$$E_{ac}(rms) = \frac{2\sqrt{2} E_o}{\pi} \dots eq(1)$$

$$I_{ac}(rms) = \frac{\pi I_o}{2\sqrt{2}} \dots eq(2)$$

$$E_o = \frac{2}{\pi} E_p = \frac{2\sqrt{2} E_{ac}(rms)}{\pi} \dots eq(3)$$

Thus, the corresponding AC Resistance illustrated as:

$$R_{ac} = \frac{E_{ac}(rms)}{I_{ac}(rms)} = \frac{8RL}{\pi^2} \dots eq(4)$$

So, the equivalent resistance at the primary side of Transformer is expressed as

$$R_e = \frac{8n^2RL}{\pi^2} \dots eq(5)$$

By application of corresponding load resistance value  $R_{ac}$  and The properties of the LCC series & parallel resonance converter can be determined using the AC analysis technique. To find out the transformer turn ratio we have the following parameters. Consider the dc bus voltage is  $V_{dc} = 400V$  and the Output voltage is  $V_{out} = 100V$  with voltage gain  $G=1$  so to find out the transformer turn ratio the following formula is considered.

$$G = \frac{n * V_{out}}{V_{dc}/2} \dots eq(6)$$

The Bus dc voltage is divided by 2 because we use the half bridge

converter configuration. For eq (6) we calculate the transformer turn ratio  $n=2$ .if the designer wants to change the output voltage means the power of the converter, then consider the Gain is unity and by the same equation calculate the transformer turn ratio with respect to the changes

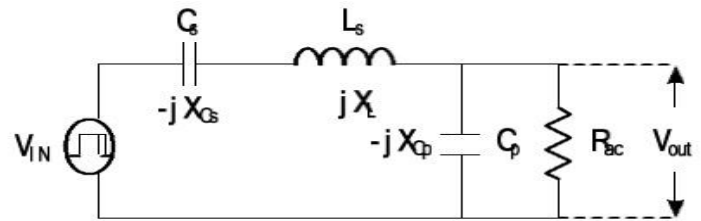

Fig. 2 Frequency domain circuit of the resonance tank

The gain of the resonance tank circuit is define by eq.(7) shown below.

$$\frac{V_{out}(rms)}{V_{in}(rms)} = \frac{1}{\{1 + \frac{X_{Cs}}{X_{Cp}} - \frac{X_{Ls}}{X_{Cp}} + j(\frac{X_{Ls}}{R_{ac}} - \frac{X_{Cs}}{R_{ac}})\}}$$

The circuit Quality factor of is well-defined as

$$Q_s = \frac{X_{Ls}}{R_L} \dots eq(7)$$

$$Q_s = 1/R_e \sqrt{L_s/C_s}$$

And the series resonance frequency is given as

$$\omega_s = \frac{1}{\sqrt{L_s C_s}}$$

Now in terms of  $\omega_s$ (Resonance Frequency) and Quality Factor  $Q_s$  the overall transfer function Voltage gain (G) can be defined as.

$$G = \frac{1}{\left[ \frac{\pi^2}{8 \left( 1 + \left( \frac{C_p}{C_s} \right) - \omega^2 L_s L_p \right)} + jQ_s \left( \left( \frac{\omega}{\omega_s} \right) - \left( \frac{\omega_s}{\omega} \right) \right) \right]}$$

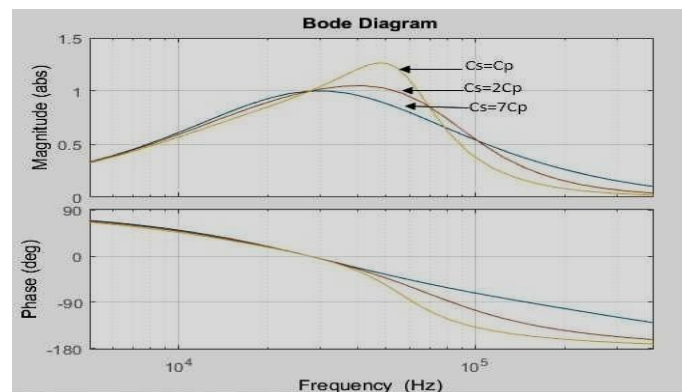
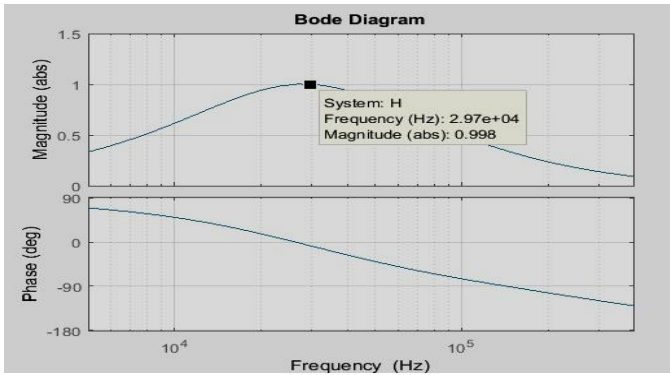

Fig. 3 The gain plot for different value of parallel capacitor

As the value of parallel capacitor increased the gain is also increased so that output power is increased if Resonant circuit operates in the inductive region so that ZVS should be achieved to minimize the switching losses at turn ON time.



**Fig. 4 Switching frequency and the gain is approximately unity**

The Resonant circuit components are Series Capacitor is  $C_s=33\text{nf}$ , Series Inductor  $L_s=1.1\text{mH}$  and parallel capacitor at Transformer output is  $C_p=4.7\text{nf}$ . The Gain and the switching frequency is  $G=1$  and  $29.7\text{ KHz}$  and the Transformer Ratio  $n=2$ .

As the Switching Frequency Increase Beyond the unit Gain Value at either side the Gain Get Reuced and Converter can not achieved Resonance Condition.

**III. EXPERIMENTAL RESULTS**

Figure 1 depicts a half-bridge LCC resonance converter. The circuit was configuration to provide 150W to a 100V output voltage using a resonance inductor  $L_s=1.1\text{mH}$ , capacitor value in series  $C_s=33\text{nF}$ , and a capacitor value in parallel at the transformer output side  $C_p=4.7\text{nF}$ . The Resonance frequency is  $27.55\text{ kHz}$ , and the input voltage is  $240\text{ Vac}$ . First, the system is simulated in MATLAB. Figure shows a simulation circuit for a series parallel LCC resonant circuit. The LCC resonant circuit's practical outcome is illustrated below.

The main side of the transformer has a voltage of 200V, while the output voltage is around 100V due to the turns ratio of  $n=2$ . The switching frequency and efficiency with variable output voltage and constant current result is shown in Table I.

S. No.	$V_{in}$ (V)	$P_i$ (W)	$V_o$ (V)	$I_o$ (A)	$P_o$ (W)	$\eta$ (%)	$f_{sw}$ (KHz)
1	240	156.1	98.61	1.46	143.9	92.18	29.82
2	240	140	87.06	1.46	127.8	91.28	35.3
3	240	128.9	79.91	1.457	116.4	90.34	37.56
4	240	110.4	67.67	1.454	98.38	89.23	40.44
5	240	101.7	61.81	1.455	89.92	88.48	41.25
6	240	71.09	40.78	1.462	59.64	84.17	43.38
7	240	64.57	36.54	1.463	53.45	82.85	43.90

**TABLE I SWITCHING FREQUENCY AND EFFICIENCY WITH VARIABLE OUTPUT VOLTAGE AND CONSTANT CURRENT RESULT**

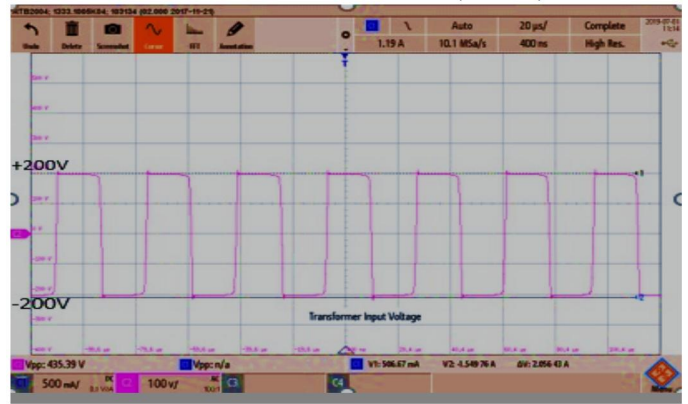

**Fig. 5 Transformer Primary side voltage**

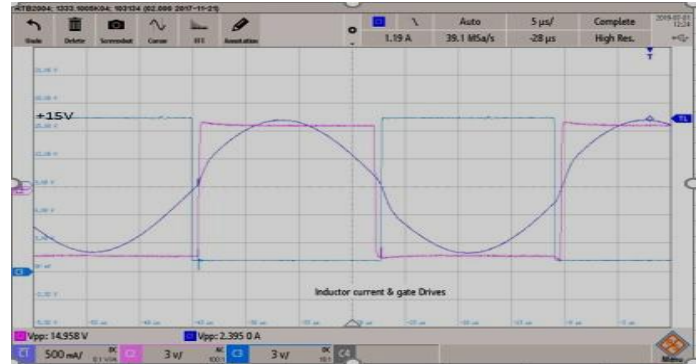
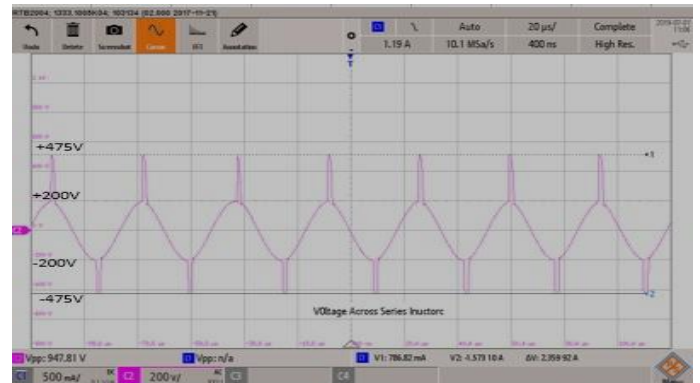

**Fig. 6 Inductor current & Gate Drive**

The Fig 6 shows the upper and lower MOSFET Gate Drive with inductor current there is time gap between the both gate Drive is the Dead band gap.

Voltage across the series inductor is shown in fig 6. The voltage in the dead band gap reach to maximum peak shoot because at that time both the MOSFET gate drive voltage reached to zero volt and there is no control over it. when the load is decreased the resonance tank circuit control the operation by is increased Switching frequency. so that LCC resonance converter are used for large voltage variation with small variation in switching frequency to control the operation.

Voltage across the transformer secondary side or voltage across the parallel capacitor  $C_p$  is around 100V.



**Fig. 7 Voltage across Series Inductor**

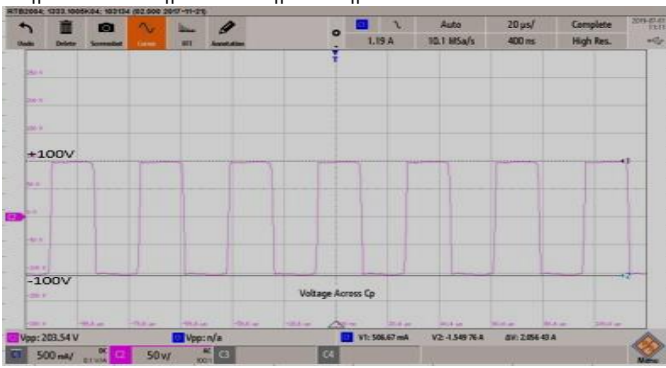

**Fig. 8** *Volate across transformer Primary side*

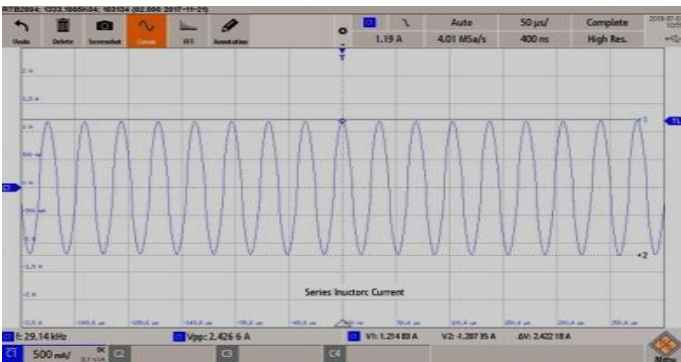

**Fig. 9** *Series Inductor  $L_s$  current*

In Fig. 9 series inductor current at the vicinity of Resonance frequency so the Switching losses is minimum means the converter functions in the inductively region as a result ZVS condition achieved and minimum loss is observed in the converter and efficiency of the converter get increased at that instant so for a resonance converter it is always to operated in the inductive region where the current is lagging.

**IV. CONCLUSION**

A half bridge type LCC resonance converter with functioning in steady state and flexible frequency controls is modelled and realised. The research demonstrates how the resonant converter can be effectively worked over a wide range of output voltage and load current. The output power can be changed from very low to very high and vice versa. The voltage and current values are at maximum value determined by element of tank circuit, and the converter efficiency and frequency have proven that the converter’s operation is limited only in a narrow area. where the converter’s resonance area is.

**V. ACKNOWLEDGEMENT**

This work is supported by APT Electronics Pvt Ltd Noida sector-58 (Director-Mr. Pawan Bothra).

**VI. REFERENCES**

1. R. L. Steigerwald, “A comparison of half-bridge resonant converter topologies,” IEEE Transactions on Power Electronics, Vol. 3, No. 2, pp. 174-182, 1988.
2. P. R. K. Chetty, “Resonant Power Supplies: Their History and Status,” IEEE Aerospace and Electronic Systems Magazine, Vol. 7, No. 4, pp. 23-29, April 1992.
3. E. X. Yang, B. Choi, F. C. Lee, and B. H. Cho, “Dynamic

analysis and control design of LCC resonant converter,” IEEE Power Electronics Specialists Conference, pp. 362-369, Vol. 129, June-3 July 1992.

4. J. Bordonau, R. M. Lamaison, and J. Peracaula, “An LCC DC/D Cresonant converter designed for applications with variable load and output voltage,” IEEE Power Electronics Specialists Conference, Vol. 1, pp. 292-297, June 1995.
5. A. J. Gilbert, C. M. Bingham, D. A. Stone, and M. P. Foster, “Normalized analysis and design of LCC resonant converters,” IEEE Transactions on Power Electronics, Vol. 22, No. 6, pp. 2386-2402, 2007.
6. J. A. Martin-ramos, J. Diaz, A. M. Pernia, J. Lopera, and F. Nuno, Dynamic and State models for the PRC-LCC resonant topology with a capacitor as output filter,” IEEE Transactions on Industrial Electronics, Vol. 54, No. 4, pp. 2262-2274, 2007.
7. Rahul Khandekar, Vasil Panov, and William G. Dunford, “A Novel Modeling Approach of LLC Resonant Converter for Embedded Controls”, Telecommunications Energy Conference (TnTELEC), IEEE 36th International, 2014.
8. C. Adragna, S. De Simone and C. Spini, “A design methodology for LLC resonant converters based on inspection of resonant tank currents” IEEE, 2008.
9. Hangseok Choi, “Design Considerations for an LLC Resonant Converter”, Power Conversion Team, Fair child Semiconductor, Fairchild Power Seminar 2007.
10. Sung-Soo Hong, Sang-Ho Cho, Chung-Wook Roh, and Sang- KyooHan-r, “Precise Analytical Solution for the peak gain of LLC Resonant Converters”, Journal of Power Electronics, Vol. 10, No. 6, November 2010.
11. Rahul Khandekar, Vasil Panov, and William G. Dunford, “A Novel Modeling Approach of LLC Resonant Converter for Embedded Controls”, Telecommunications Energy Conference (TnTELEC), IEEE 36th International, 2014.